

## **Sun Tap Water Systems**



## **WS1 Clack Water Softener Owners Manual**

## MAIN COMPONENTS

Your water treatment system is a point of entry (POE) system composed of three components:

- A. The control valve and computer assembly
- B. The fiberglass tank assembly including the water treatment medium
- C. The brine tank assembly including brine valve

Each of these assemblies has a specific function as described below:

**Control Valve Assembly...**Automatically monitors water usage patterns, initiates regeneration and moves the valve through the steps of regeneration.

**Media Tank Assembly...** A fiberglass vessel, which contains the water softening media, in the proper diameter and depth of the media and evenly distributes the feed water throughout the media tank assembly.

**Brine Tank Assembly...**A polyethylene vessel, which is used to dissolve salt and to hold the proper amount of brine for the next regeneration. A brine valve keeps the control valve from drawing air into the system.

## STEPS OF OPERATION

**Service...**Hard water flows downward through the water softening resin where the hardness minerals, calcium and magnesium, as well as dissolved iron, are removed from the water and are collected on the resin. The amount of resin and the salt dosage gives resin a certain capacity for hardness and iron removal.

**Backwash 1 ...**During the cycle the water flows upward through the resin bed and washes collected sediment or other foreign material to the drain.

**Brine and Rinse...**The brine solution is drawn from the brine tank and slowly flows downward through the resin collecting the hardness and iron as it goes. The brine carries the hardness and iron with it and rinses them to the drain.

**Backwash 2 ...**Same as backwash 1 above but of slightly shorter duration.

**Fast Rinse...**Water flows downward through the resin and to the drain carrying with it the remaining traces of brine.

**Brine Tank Refill...**A predetermined volume of water flows into the brine tank and dissolves a calculated amount of salt creating brine for the next generation. This occurs at the onset of the next **Service** cycle. Be sure that there is always undissolved salt remaining. Since the frequency of regeneration is reasonably consistent, a regular addition of salt should be scheduled. Approximately 6"-8" of salt must be in brine tank. In some cases the installation technician may decide a pre-brine refill may be appropriate. If so brine refill will occur 2 hours prior to regeneration and will result in minimal water in the brine tank assembly during service position.

**Total Regeneration Time** (Backwash 1 through Fast Rinse) can be anywhere between 57 and 107 minutes depending on setting made for certain water conditions.

## NORMAL OPERATING DISPLAYS

### GENERAL OPERATION

When the system is operating one of two displays will be shown. Pressing NEXT will alternate between displays. One of the displays is the current time of day. Depending on the system's configurations, the second display is one of the following: days remaining or gallons remaining. Days remaining is the amount of days left before the system goes through a regeneration cycle. Capacity remaining is the number of gallons that will be treated before the system goes through a regeneration cycle. The user can scroll between the displays using NEXT.

If the system has called for a regeneration that day, regeneration will occur at the preset time of regeneration, the words REGEN TODAY will appear on the display.

When water is being treated (i.e. water is flowing through the system) the word "Softening" or "Filtering" flashes on the display.

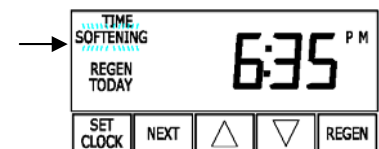

REGEN TODAY will show if a regeneration is expected "Tonight".

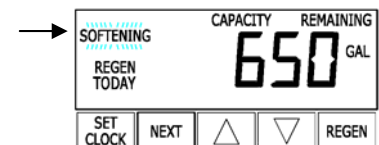

# GENERAL CARE AND MAINTENANCE INFORMATION

The following guidelines are recommended for you to obtain maximum efficiency from your water treatment system:

1. **Control Valve...** Try to keep free of dirt and debris both on valve body and under cover. No lubrication is required.
2. **Brine Tank ...** A major cleaning is recommended every two years. This interval may need to be adjusted depending on the amount of insoluble material in the salt being used.
  - A. Allow salt level to become very low so there is little to remove. Scoop out undissolved salt.
  - B. Disconnect and remove brine valve. There is no pressure or suction on this line except during a regeneration.
  - C. Remove internal parts of brine tank, if any.
  - D. Clean brine tank interior with a mild cleaning agent (dish soap) and rinse thoroughly.
  - E. Replace brine valve and internal parts.
  - F. Pour five gallons of water (softened if available) into the tank (Add only two gallons if pre-brine refill option is used).
  - G. Add salt.
  - H. Replace cover.
  - I. Allow two hours for concentrated brine to be made before next regeneration.
  - J. It is recommended that... a manually initiated regeneration should be started now. See **Manual Regeneration**.
3. **Salt / Potassium Supply...**For continuous treated water, the brine tank must have an adequate supply of salt at all times. This requires checking and refilling at regular intervals, to at least keep between 6" – 8" of salt and 12" of potassium in the tank. Although your system is designed to work with all types of salt, recommend pellet salt for outside installations. If usage is less than 50 lbs. a month, **do not fill over half full of salt or potassium**.
4. **Resin Cleaning...** All water contains contaminants which depending on their specific nature and on the amount of water used, will adhere to the spherical resin beads, thereby reducing the available surface area and the resin's effectiveness to soften water. This is particularly true if iron is present in the water. Without a periodic cleaning, the life expectancy and performance of the resin may be reduced. Therefore it is recommended that a resin-cleaning agent be used once per year unless the water is a city supply with no iron. If the iron level is very high, the resin may require an automatic resin cleaning solution to be dispensed to brine solution and will need to be checked and maintained during monitoring of salt usage. See directions on refill solution or dispenser in brine tank.

5. **Vacations...** Your water softener regenerates after a preset volume of water is used or after fourteen days have passed. Unless you are going on an extended trip, it's best to allow the regeneration to take place after fourteen days. If water will not be used for an extended period of time or if there is a concern about having the system regenerate in your absence, then place the handles of the bypass valve in the **"BYPASS OPERATION"** mode as shown below. Also use this mode **When Untreated Water is Desired**. It is not necessary to unplug water conditioner when water is turned off or on by pass.

**NORMAL OPERATION**

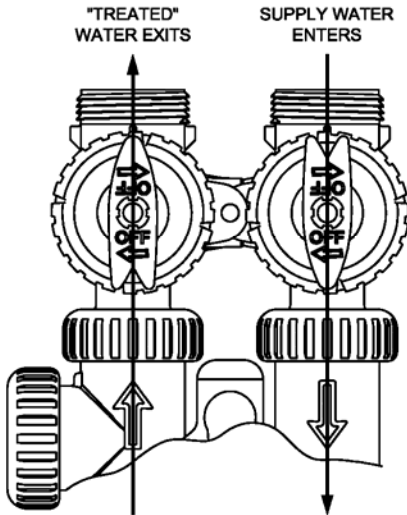

**BYPASS OPERATION**

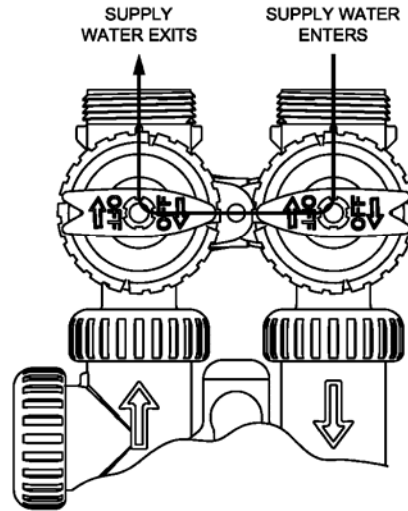

**DIAGNOSTIC MODE**

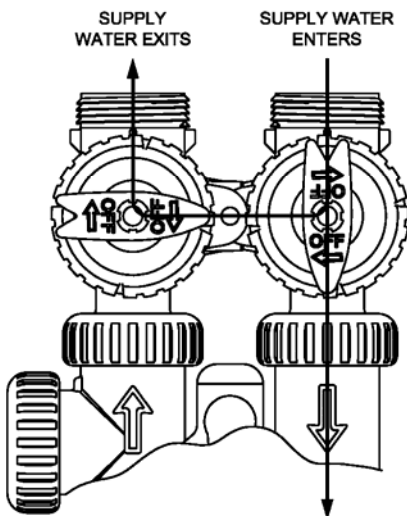

**SHUT OFF MODE**

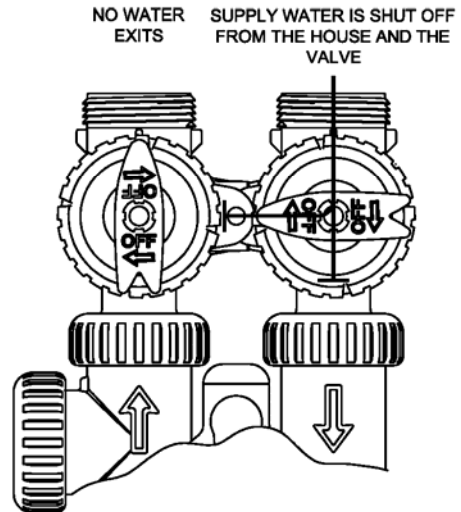

(Can be used as soft water turn-off during extended periods when the home is not being occupied.)

6. **Protection from Weather...**Water inside your control valve, resin tank, or brine tank must not freeze. Like any other part of your plumbing system, these pipes, tubes or valves can burst and leak if allowed to freeze. Electronics should be protected from any sunlight with the optional cover, which should be provided if necessary by installer.
7. **Power Failure...**If there is power failure or if the system is unplugged for less than two hours, all settings including the time of day will be retained in the system memory. If there is a power outage or the wall transformer are disrupted for greater than two hours, the time of day will flash and requires resetting. The nonvolatile EEPROM memory will retain all other factory, dealer and installer settings.

8. **Set Time of Day...**

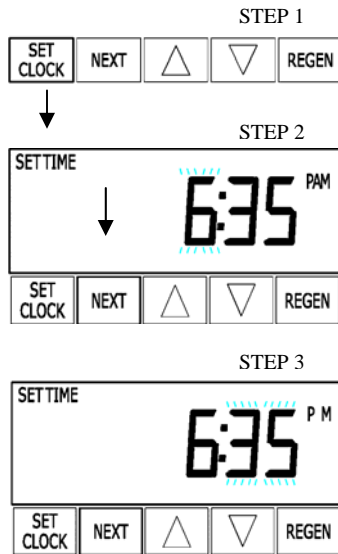

**TIME OF DAY**

Time of day should only need to be set after extended power outages or when daylight saving times begins or ends. If an extended power outage occurs, the time of day will flash on and off indicating that the time should be reset.

**STEP 1-** Press SET CLOCK

**STEP 2-** Current Time (hour): Set the hour of day using ∇ or Δ buttons. AM/PM toggles after 12. Press NEXT to go to step 3.

**STEP 3-** Current time (minutes): Set the minutes using ∇ or Δ buttons. Press NEXT to exit Set Clock. Press REGEN to return to previous step.

9. **Manual Regeneration...**Sometimes there is a need for regeneration before the control valve calls for it usually referred to as “manual regeneration”. This is needed when a period of heavy water usage is anticipated or when the system has been operated without salt.

- To initiate a manual regeneration at the present delayed regeneration time (usually around 2:00 a.m.), press and release “REGEN”. The words “REGEN TODAY” will flash on the display to indicate that the system will regenerate at the present delayed regeneration time.
- If you pressed the “REGEN” button in error, pressing the button again will cancel the command.
- To initiate a manual regeneration immediately, press and hold the “REGEN” button for three seconds.

The system will begin to regenerate immediately. This command cannot be canceled.

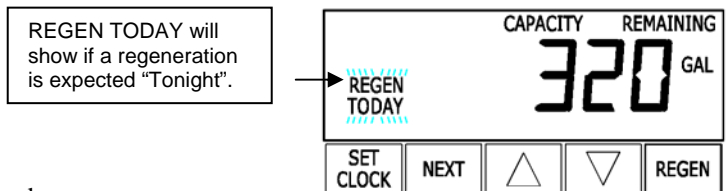

10. **Error Display...**If the word “ERROR” and a code number for instant: (Example 1003) appears in the display, contact the dealer or manufacturer for help. This indicates that the control valve is not able to function properly and the code number 1003 is the general nature of the problem. Contact your dealer for service.

11. **Drain Line...**Any crimping, freezing, or blocking of this line will cause a malfunction of your water treatment system. Check occasionally.

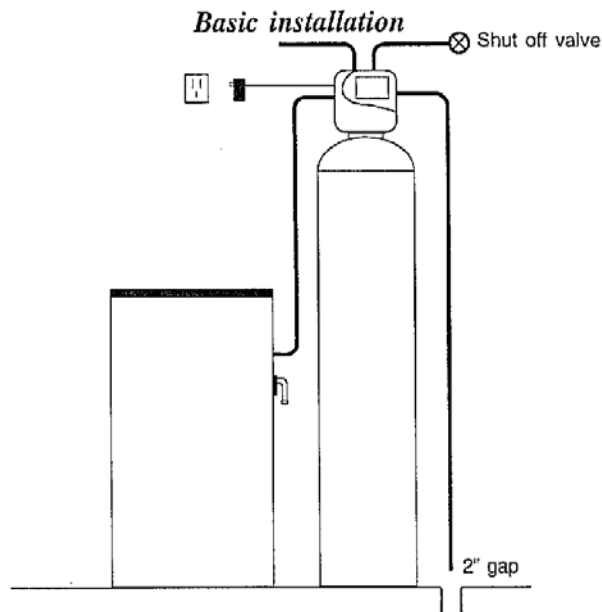
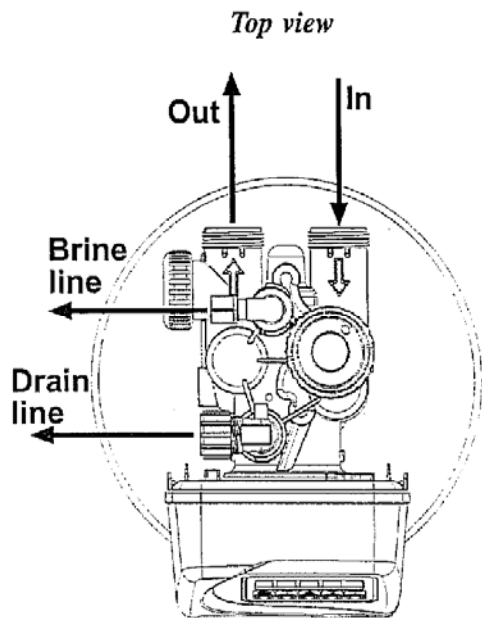

### GENERAL INSTALLATION & SERVICE CAUTIONS



The control valve, fittings, and/or bypass are designed to accommodate minor plumbing misalignments they are not designed to support the weight of a system or the plumbing.



Do not use Vaseline, oils, other hydrocarbon lubricants, or silicone spray anywhere. **Do not use silicone on red or clear lip seals.**



**Do not use pipe dope or other sealant on threads.** Teflon tape must be used on the threads of the 1" NPT elbow, its 1/4" NPT connections, and on the threads for the drain line connection. Teflon tape is not used on the nut connections or caps because o-ring seals are used. The nuts and caps are designed to be unscrewed or tightened by hand or with the special plastic Service Wrench, CLV-V3193. If necessary, pliers can be used to unscrew the nut or cap. **Do not use a pipe wrench** to tighten nuts or caps. **Do not place screwdriver in slots, on caps, and/or tap with a hammer.**

### SITE REQUIREMENTS

- Water Pressure, 20-125 psi
- Water Temperature, 40°-110° F
- The tank should be on a firm level surface
- Electrical: Use a 115/120V, 60Hz uninterrupted outlet.

- Current draw is 0.25 amperes
- A 15 ft. power cord is furnished
- The plug-in transformer is for dry locations only.
- Batteries are not used.

1. The distance between the drain and the water conditioner should be as short as possible.
2. Since salt must be periodically added to the brine tank, the tank should be located where it is easily accessible.
3. Do not install any water conditioner with less than 10 feet of piping between its outlet and the inlet of a water heater.
4. Do not locate unit where it or its connections (including the drain and overflow lines) will be subjected to temperatures at or below 34°F.

5. The use of resin cleaner in an unvented enclosure is not recommended.
6. Do not install equipment in locations that would receive rain run-off from roof.
7. **INLET/OUTLET PLUMBING:** Connect to a supply line downstream of outdoor spigots. Install an inlet shutoff valve and plumb to the units bypass valve inlet located at the right rear as you face the unit. When assembling the installation-fitting package (inlet and outlet), connect the fitting to the plumbing system first and then attach the nut, split ring and o-ring. Heat from soldering or solvent cements will damage the nut, split ring or o-ring. Solder joints should be cool and solvent cements should be set before installing the nut, split ring and o-ring. Avoid getting solder flux, primer, and solvent cement on any part of the o-rings, split rings, bypass valve, or control valve. If the building's electrical system is grounded to the plumbing install a copper-grounding strap from the inlet to the outlet pipe. **Plumbing must be done in accordance with all applicable local codes.**
8. **DRAIN LINE:** First, be sure that the drain can handle the backwash flow of the system. Solder joints near the drain must be located prior to connecting the drain line flow control fitting. Leave at least 6" between the drain line flow control fitting and solder joints. Failure to do so could cause interior damage to the flow control. Install a 3/8"-1/2" I.D. flexible plastic tube to the Drain Line Assembly or discard the tubing nut and use the 3/4" NPT fitting for rigid pipe. If the backwash rate is greater than 7 gpm, use a 3/4" drain line. Run drain tube to its discharge point in accordance with plumbing codes. Pay special attention to codes for air gaps and antisiphon devices.
9. **BRINE TANK CONNECTION:** Install a 3/8" O.D. polyethylene tube from the Refill Elbow to the Brine Valve in the brine tank.

10. **OVERFLOW LINE CONNECTION:**

AN OVERFLOW DRAIN LINE IS RECOMMENDED ANYWHERE A BRINE OVERFLOW COULD DAMAGE FURNISHINGS OR THE BUILDING STRUCTURE.

Your softener is equipped with a brine tank safety float, which greatly reduces the chance of an accidental brine overflow. In the event of a malfunction, an **OVERFLOW LINE CONNECTION** will direct the "overflow" to the drain instead of spilling on the floor. This barb type fitting should be on the side of the cabinet or the brine tank.

To connect the overflow fitting, locate the hole inside of brine tank. Insert overflow fitting into tank and tighten with plastic thumbnut from the inside. Attach a length of 1/2" I.D. tubing (not supplied) to the fitting and run to drain. Do not elevate overflow line higher than 3" below bottom of overflow fitting. Do not connect this tube into the drain line of the control valve. Overflow should be a direct, separate line from overflow fitting to drain, sewer, tub, or appropriate outdoor location. Allow an air gap as per the drain line instructions.

**IMPORTANT:**



**Never insert a drain line directly into a drain, sewer line, or trap. Always allow an air gap between the drain line and the wastewater to prevent the possibility of sewage being back-siphoned into the water conditioner.**

## WHAT TO DO BEFORE CALLING FOR A REPAIR

If you suspect that your water treatment system is not working properly, the following routine check should be made before calling for repair. This may save you time and possibly the cost of a service call.

1. Check for softness with the test kit given to you at time of installation.
2. **Brine Tank...**If not enough salt, add salt or call for a salt delivery. If dirty, clean as described under GENERAL CARE & SELF-SERVICE information.
3. **Electrical Connection...**Be sure that the plug-in wall transformer is securely plugged into a wall receptacle which is NOT controlled by a switch which may be turned off at times. If the display screen is blank, power is currently off. The system's computer retains information in memory for two hours during an outage and then redisplay the information when power is restored. Thus, you may not know the power was off during that short period. If time of day is flashing, power was out for more than two hours. Reset time. Check fuses, circuit breakers, plug-in transformer, etc. Since you may not know how long the power was out, start a manual regeneration at this time to restore capacity to the system and manually cycle once a day for 3 continuous days.
4. **Bypass Valve...**See bypass valve diagrams under "**Vacation**" to be sure that the system is not being bypassed with untreated water. The valve handles should be in the **NORMAL OPERATION** position.
5. **Unit is in Regeneration...**If water is running to the drain the unit may be regenerating, in which case it will deliver untreated water to the building. If regeneration is underway, water flow should cease within 2 hours and treated water will be available. The above condition indicates that the time of day is set incorrectly. Reset time of day. If time of day is correct, then the time of regeneration may be set incorrectly. Call dealer to reset this setting. If water does not stop flowing to the drain within 2 hours, then there is an internal leak and a service technician must be called.
6. **Exhausted Capacity...**If none of the above system checks identify the problem, start a manual regeneration. Call for service if the manual regeneration does not produce or maintain treated water.



Drawing No.	Order No.	Description	Quantity
1	V3175-01	WS1 Front Cover ASY	1
2	V3107-01	WS1 Motor	1
3	V3106-01	WS1 Drive Bracket&Spring Clip	1
4	V3108	WS1 PC Board	1
5	V3110	WS1 Drive Gear 12x36	3
6	V3109	WS1 Drive Gear Cover	1
	V3002	WS1 Drive ASY	*
Not Shown	V3186	WS1 Transformer 110V-12V	1

\* Drawing number parts 2 through 6 may be purchased as a complete assembly, part V3002.

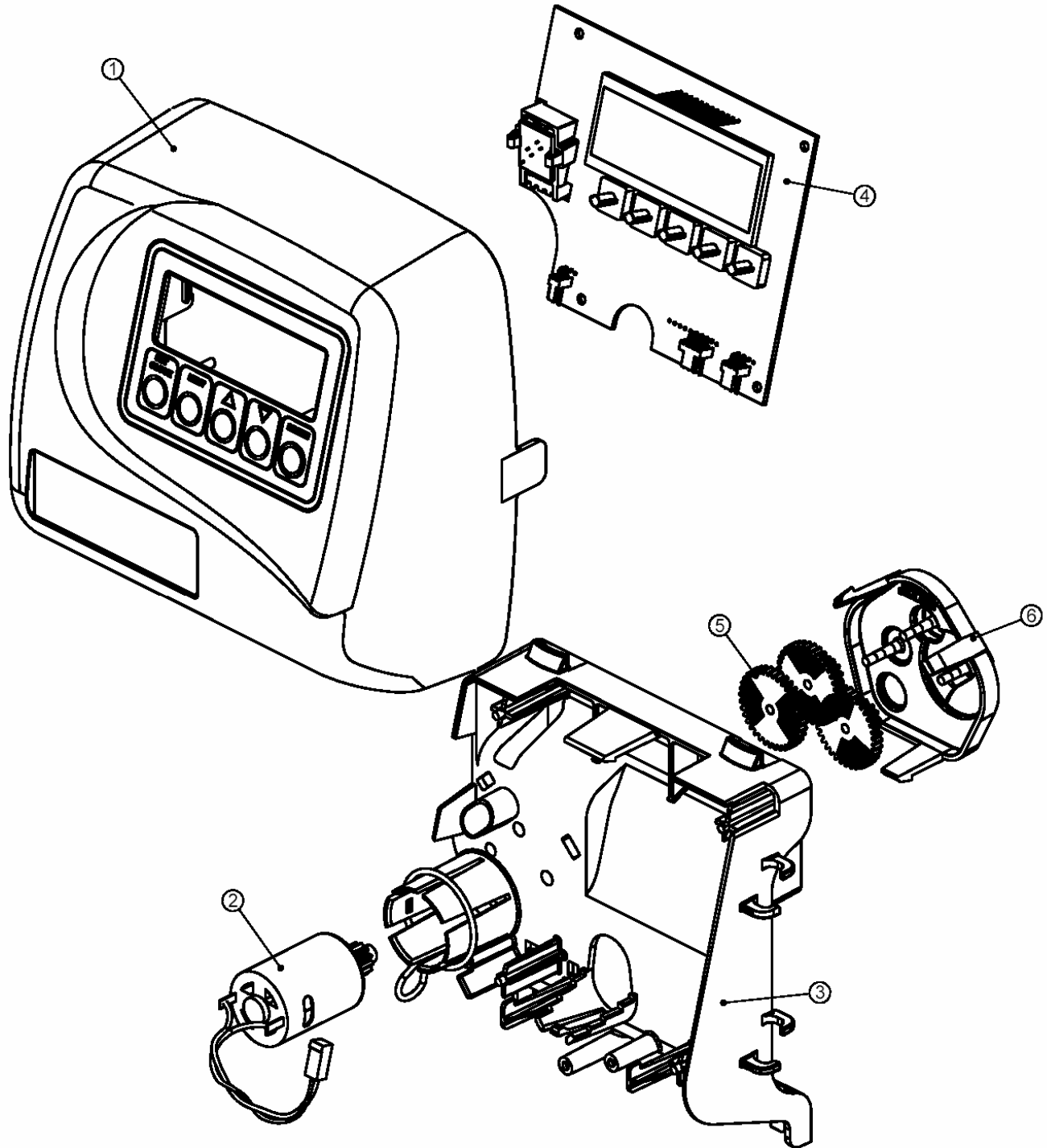

Drawing No.	Order No.	Description	Quantity
1	V3005	WS1 Spacer Stack Assembly	1
2	V3004	Drive Cap ASY	1
3	V3135	O-ring 228	1
4a	V3011*	WS1 Piston Downflow ASY	1
4b	V3011-01*	WS1 Piston Upflow ASY	1
5	V3174	WS1 Regenerant Piston	1
6	V3180	O-ring 337	1

\*V3011 is labeled with DN and V3011-01 is labeled with UP.  
 Note: The regenerant piston is not used in backwash only applications.

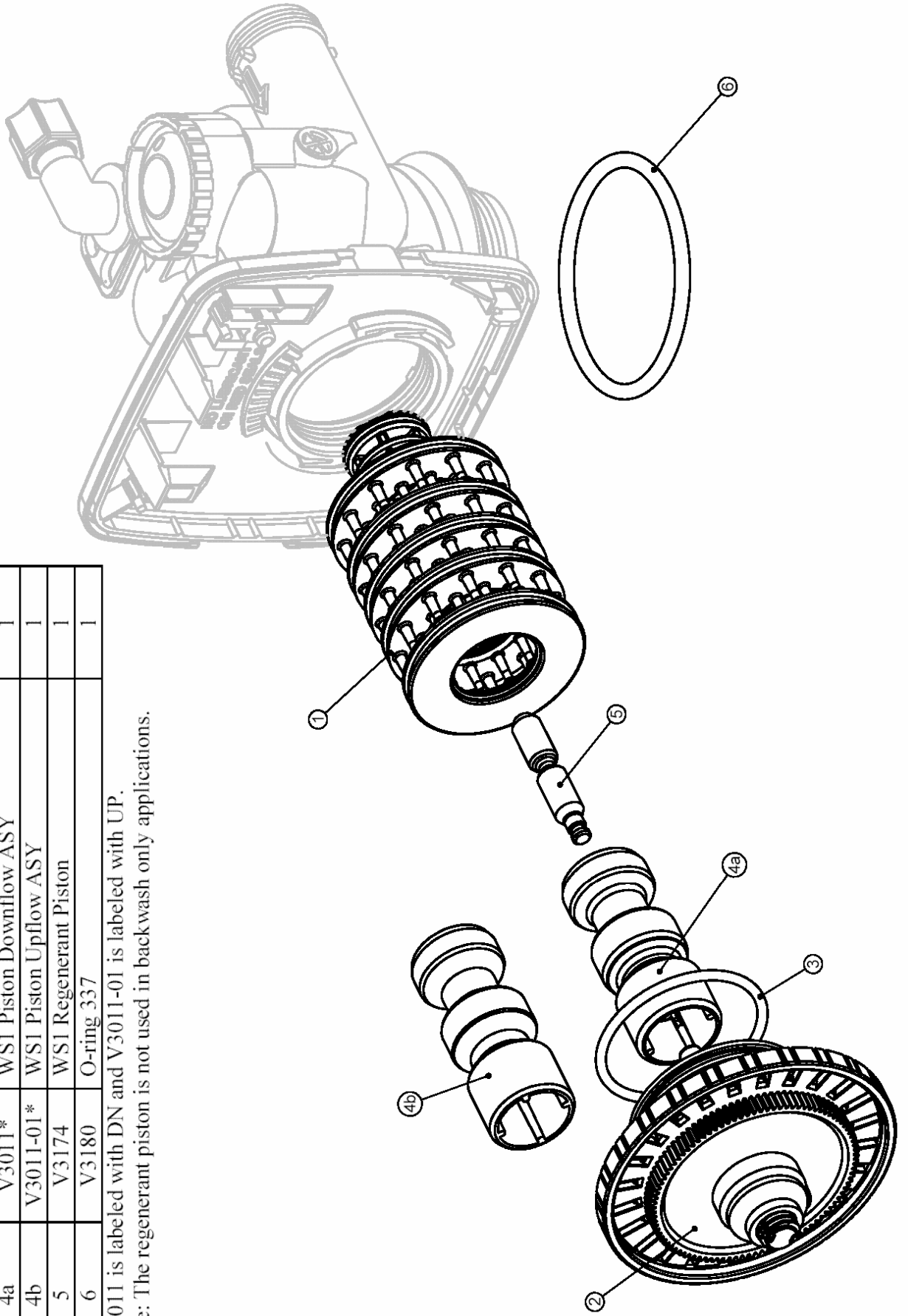

Drawing No.	Order No.	Description	Quantity
1	V3176	Injector Cap	1
2	V3152	O-ring 135	1
3	V3177	Injector Screen	1
4	V3010-IZ	WSI Injector ASY Z PLUG	1
	V3010-IA	WSI INJECTOR ASY A BLACK	
	V3010-IB	WSI INJECTOR ASY B BROWN	
	V3010-IC	WSI INJECTOR ASY C VIOLET	
	V3010-ID	WSI INJECTOR ASY D RED	
	V3010-IE	WSI INJECTOR ASY E WHITE	
5	V3010-IF	WSI INJECTOR ASY F BLUE	1
	V3010-IG	WSI INJECTOR ASY G YELLOW	
	V3010-IH	WSI INJECTOR ASY H GREEN	
	V3010-II	WSI INJECTOR ASY I ORANGE	
	V3010-IJ	WSI INJECTOR ASY J LIGHT BLUE	
	V3010-IK	WSI INJECTOR ASY K LIGHT GREEN	
Not Shown	V3170	O-ring 011	*
Not Shown	V3171	O-ring 013	*

\*The injector plug and the injector each contain one 011 (lower) and 013 (upper) o-ring.

Note: For downflow, injector is located in the down hole and injector plug in the up hole. For a filter that only backwashes, injector plugs are located in both holes, and regenerant piston must be removed.

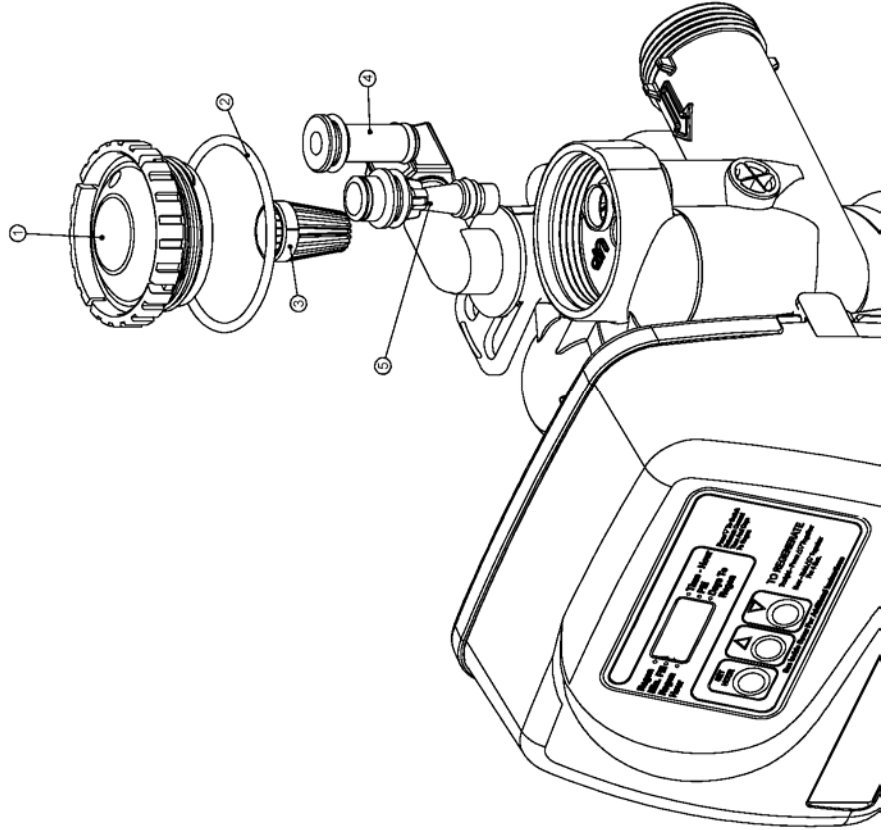

Drawing No.	Order No.	Description	Quantity
1	V3195-01	WSI Refill Port Plug ASY	This part is required for backwash only systems
2	H4615	Elbow-Locking Clip	1
3	JCP-P-6	Polytube insert 3/8	1
4	JCPG-6PBLK	Nut 3/8	1
5	H4613	Elbow Cap 3/8	1
6	V3163	O-ring 019	1
7	V3165-01*	WSI RFC Retainer ASY	1
8	V3182	WSI RFC	1
Not Shown	H4650	Elbow 1/2" with nut and insert	Option

\*Assembly includes WSI RFC.

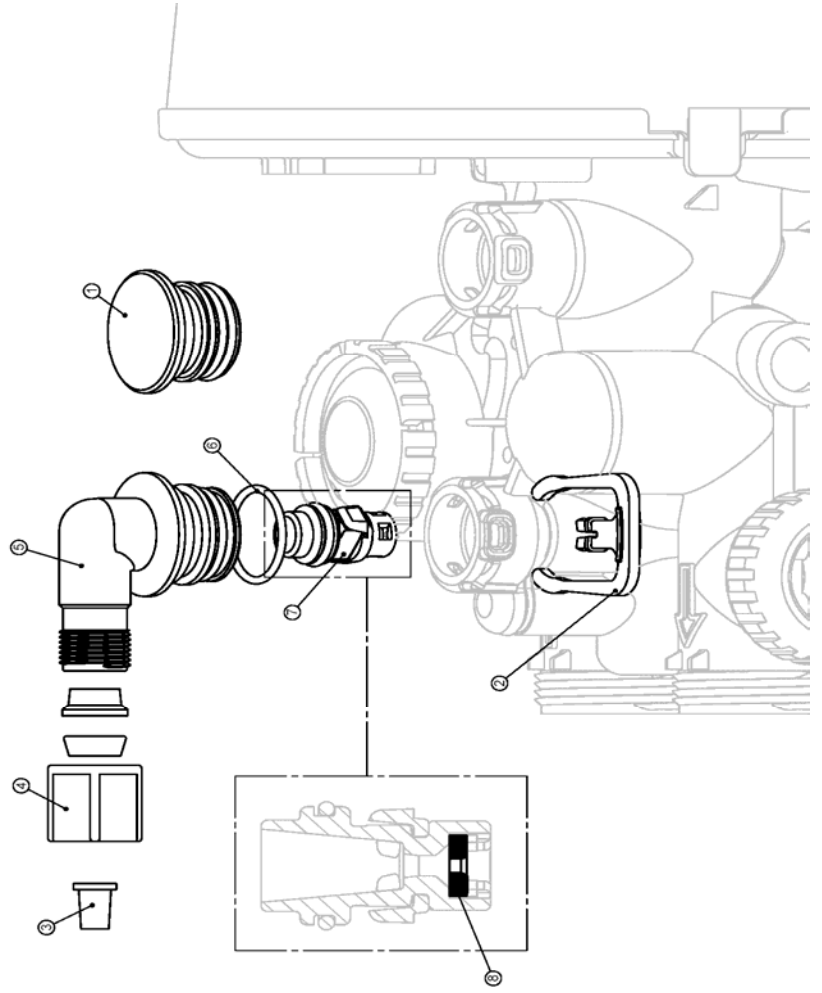

Drawing No.	Order No.	Description	Quantity
1	H4615	Elbow Locking Clip	1
2	PKP10TSS-BULK	Polytube insert 5/8	Option
3	V3192	WSI Nut 3/4 Drain Elbow	Option
4	V3158-01	WSI Drain Elbow 3/4 Male ASY	1
5	V3163	0-ring 019	1
6	V3159-01	WSI DLFC Retainer ASY	1
	V3162-007	WSI DLFC 0.7 gpm for 3/4	One DLFC must be used if fitting is used
	V3162-010	WSI DLFC 1.0 gpm for 3/4	
	V3162-013	WSI DLFC 1.3 gpm for 3/4	
	V3162-017	WSI DLFC 1.7 gpm for 3/4	
	V3162-022	WSI DLFC 2.2 gpm for 3/4	
	V3162-027	WSI DLFC 2.7 gpm for 3/4	
	V3162-032	WSI DLFC 3.2 f gpm or 3/4	
	V3162-042	WSI DLFC 4.2 gpm for 3/4	
	V3162-053	WSI DLFC 5.3 gpm for 3/4	
	V3162-065	WSI DLFC 6.5 gpm for 3/4	
	V3162-075	WSI DLFC 7.5 gpm for 3/4	
	V3162-090	WSI DLFC 9.0 gpm for 3/4	
	V3162-100	WSI DLFC 10.0 gpm for 3/4	

Valves are shipped without drain line flow control (DLFC) – install DLFC before using. Valves are shipped without 3/4" nut for drain elbow (polytube installation only) and 5/8" polytube insert (polytube installation only).

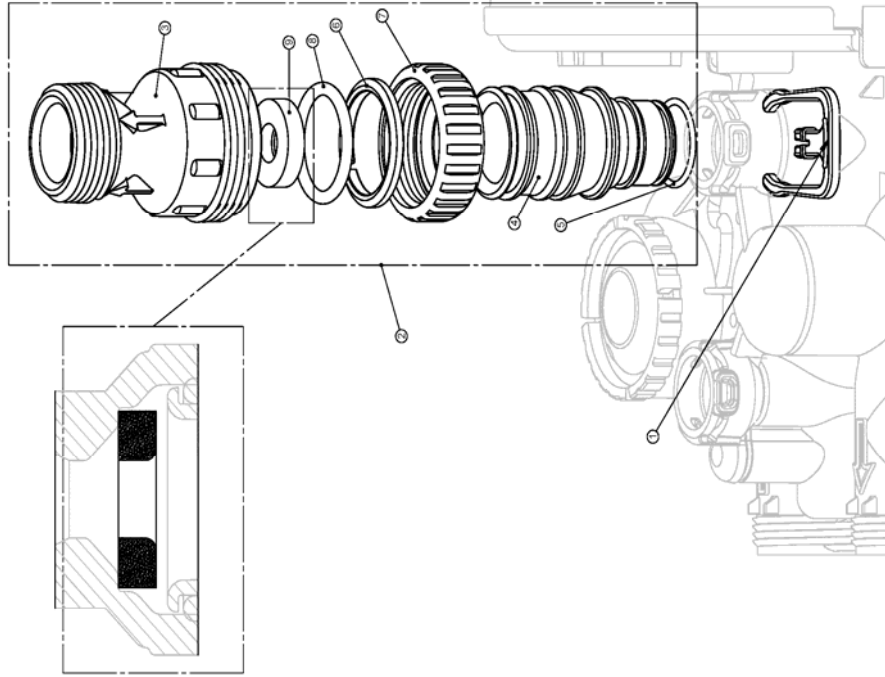

Drawing No.	Order No.	Description	Quantity
1	H4615	Elbow Locking Clip	1
2	PKP10TSS-BULK	Polytube insert 5/8	Option
3	V3192	WSI Nut 3/4 Drain Elbow	Option
4	V3158-01	WSI Drain Elbow 3/4 Male ASY	1
5	V3163	0-ring 019	1
6	V3159-01	WSI DLFC Retainer ASY	1
	V3162-007	WSI DLFC 0.7 gpm for 3/4	One DLFC must be used if fitting is used
	V3162-010	WSI DLFC 1.0 gpm for 3/4	
	V3162-013	WSI DLFC 1.3 gpm for 3/4	
	V3162-017	WSI DLFC 1.7 gpm for 3/4	
	V3162-022	WSI DLFC 2.2 gpm for 3/4	
	V3162-027	WSI DLFC 2.7 gpm for 3/4	
	V3162-032	WSI DLFC 3.2 f gpm or 3/4	
	V3162-042	WSI DLFC 4.2 gpm for 3/4	
	V3162-053	WSI DLFC 5.3 gpm for 3/4	
	V3162-065	WSI DLFC 6.5 gpm for 3/4	
	V3162-075	WSI DLFC 7.5 gpm for 3/4	
	V3162-090	WSI DLFC 9.0 gpm for 3/4	
	V3162-100	WSI DLFC 10.0 gpm for 3/4	

Valves are shipped without drain line flow control (DLFC) – install DLFC before using. Valves are shipped without 3/4" nut for drain elbow (polytube installation only) and 5/8" polytube insert (polytube installation only).

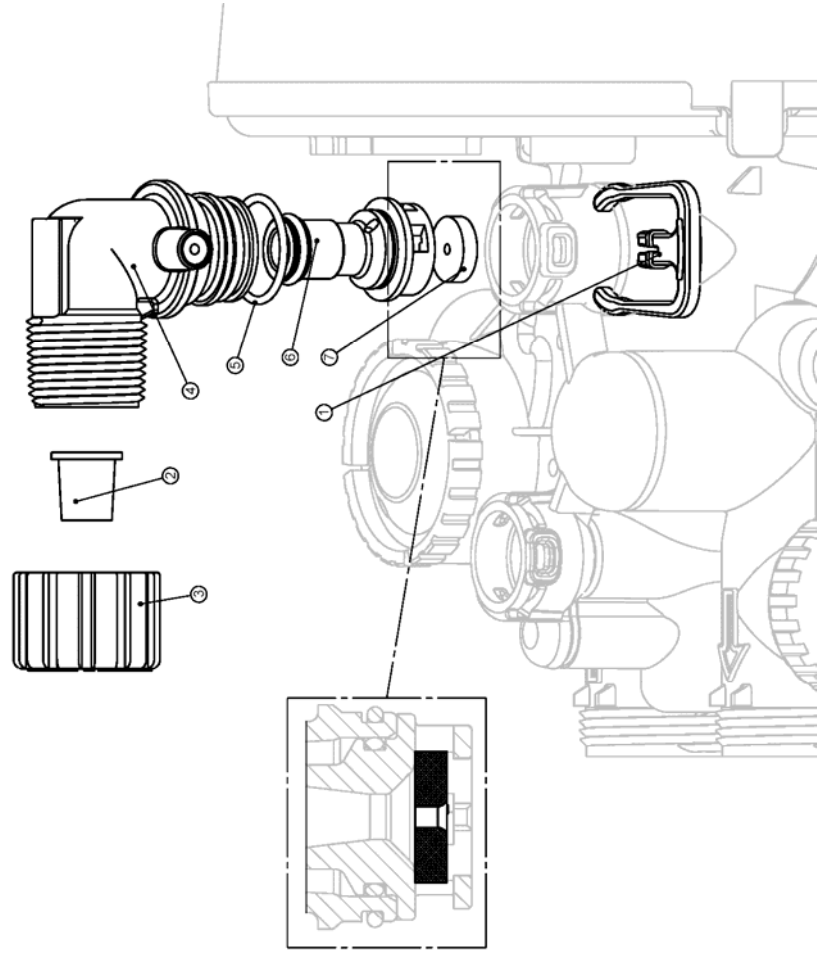

Drawing No.	Order No.	Description	Quantity
1	V3151	WS1 Nut 1" QC	1
2	V3003*	WS1 Meter ASY	1
3	V3118-01	WS1 Turbine ASY	1
4	V3105	O-ring 215	1
5	V3003-01	WS1 Meter Plug ASY	1

\*Order number V3003 includes V3118-01 and V3105.

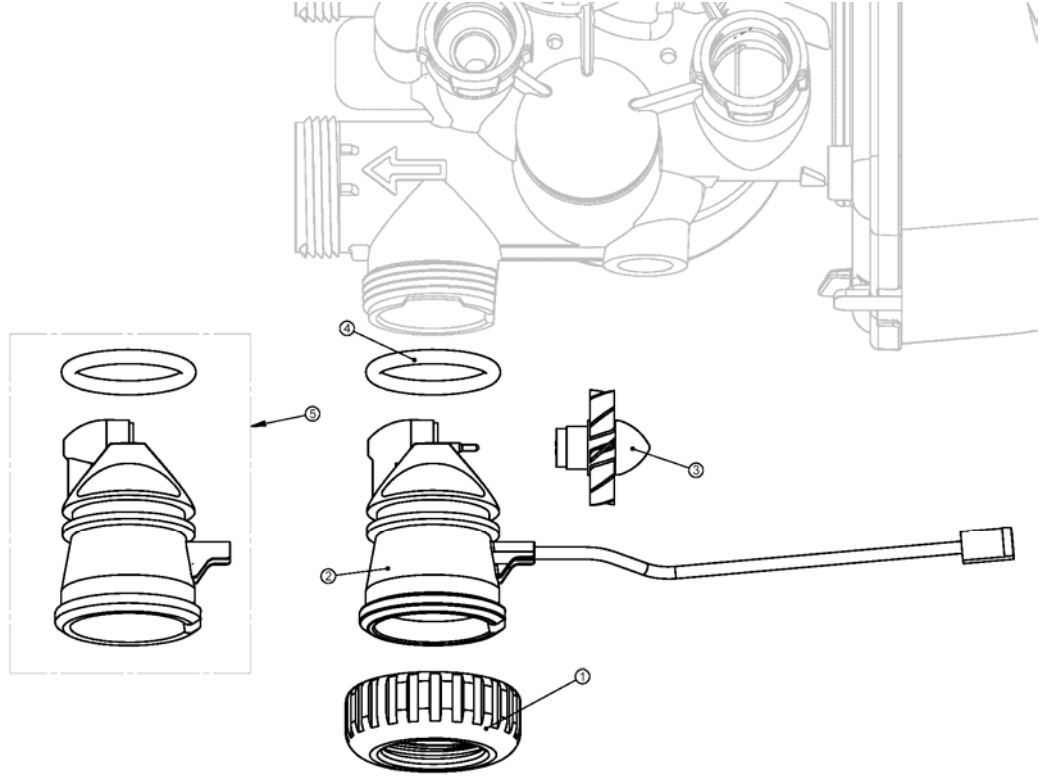

Order No: V3007  
Description: **WS1 Fitting 1" PVC Male NPT Elbow Assembly**

Drawing No	Order No.	Description	Quantity
1	V3151	WS1 Nut 1" Quick Connect	2
2	V3150	WS1 Split Ring	2
3	V3105	O-Ring 215	2
4	V3149	WS1 Fitting 1 PVC Male NPT Elbow	2

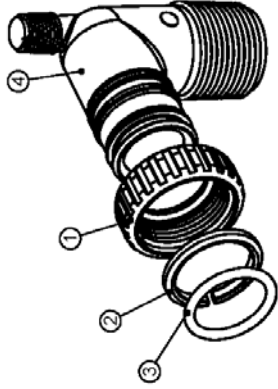

Order No: V3007-01  
Description: **WS1 Fitting 3/4" & 1" PVC Solvent 90° ASY**

Drawing No.	Order No.	Description	Quantity
1	V3151	WS1 Nut 1" Quick Connect	2
2	V3150	WS1 Split Ring	2
3	V3105	O-Ring 215	2
4	V3189	WS1 Fitting 3/4" & 1" PVC Solvent 90°	2

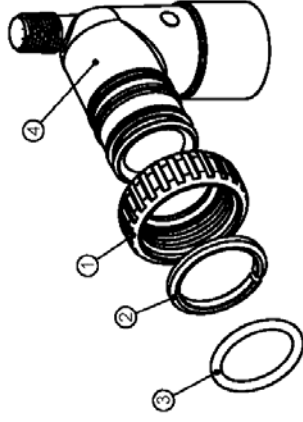

Order No: V3007-02  
Description: **WS1 Fitting 1" Brass Sweat Assembly**

Drawing No.	Order No.	Description	Quantity
1	V3151	WS1 Nut 1" Quick Connect	2
2	V3150	WS1 Split Ring	2
3	V3105	O-Ring 215	2
4	V3188	WS1 Fitting 1 Brass Sweat	2

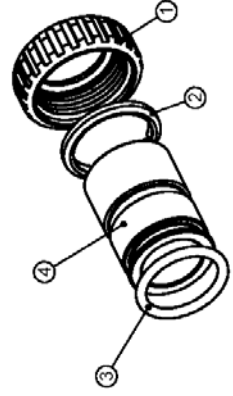

Order No: V3007-03  
Description: **WS1 Fitting 3/4" Brass Sweat Assembly**

Drawing No.	Order No.	Description	Quantity
1	V3151	WS1 Nut 1" Quick Connect	2
2	V3150	WS1 Split Ring	2
3	V3105	O-Ring 215	2
4	V3188-01	WS1 Fitting 3/4 Brass Sweat	2

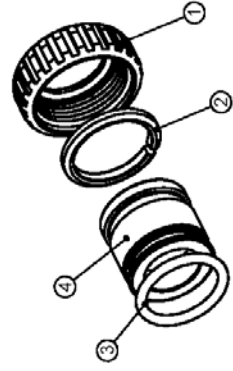

Drawing No.	Order No.	Description	Quantity
1	V3151	WS1 Nut 1" Quick Connect	2
2	V3150	WS1 Split Ring	2
3	V3105	O-Ring 215	2
4	V3145	WS1 Bypass 1" Rotor	2
5	V3146	WS1 Bypass Cap	2
6	V3147	WS1 Bypass Handle	2
7	V3148	WS1 Bypass Rotor Seal Retainer	2
8	V3152	O-ring 135	2
9	V3155	O-ring 112	2
10	V3156	O-ring 214	2

(Not Shown) Order No. V3191-01, Description: WS1 Bypass Vertical Adapter Assembly

Order No.	Description	Quantity
V3151	WS1 Nut 1" Quick Connect	2
V3150	WS1 Split Ring	2
V3105	O-Ring 215	2
V3191-01	WS1 Bypass Vertical Adapter Assembly	2

